

Faecal Immunochemical Test: Step-by-step instructions.

What is a Faecal Immunochemical Test (FIT)?

The Faecal Immunochemical Test [FIT] detects small amounts of blood in your poo sample, which you would not normally see or be aware of.

Your GP has arranged for you to have this test because of the abdominal (tummy) complaints or other symptoms that you have discussed with them. This might be pain, discomfort or changes in bowel habit.

How do I collect my sample?

Collecting your sample is very simple and hygienic. We only need a small amount of poo for the test. Please follow the instructions on the back of this leaflet.

What do I do with my collected sample?

Please return the sample to your GP practice as soon as possible. It will then be sent to the laboratory at your local hospital for testing.

What happens next?

Your GP will contact you with the result of the test. They will then discuss the next steps with you. If the test is positive then further tests may be arranged to find the source of the bleeding.

How to do your test

1

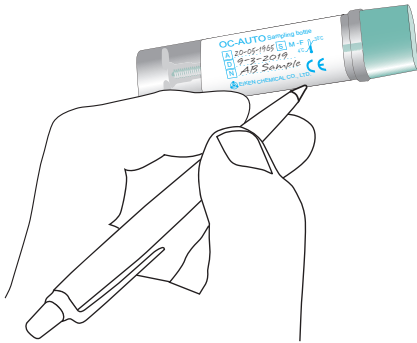

- Clearly write your name, date of birth and the date the sample was taken on the sample container.
- N = name, A = date of birth, D = date the sample was taken

2

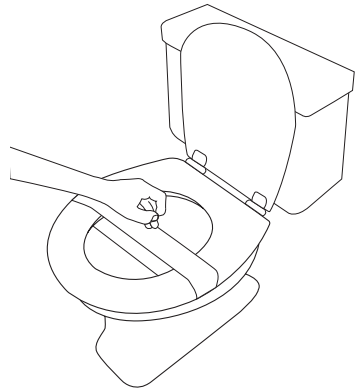

- Slip the faecal band over the toilet seat towards the back and gently press down

3

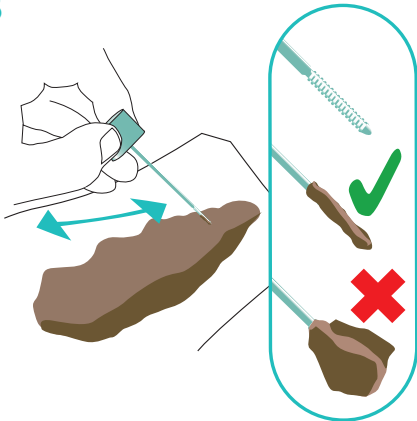

- Collect sample by scraping the green stick along the poo until all the grooves are covered.
- We only need a little poo to test - **please do not add extra!**

4



- Put stick back in container and 'click' the green cap to close it.
- Place sample container into the plastic pouch and seal.
- Place the plastic pouch **and the request form** into the card envelope and seal.

Return pack to your GP as soon as possible.